

ALYSIUM PRODUCT DOCUMENT SPECIFICATION PACK

This Document Pack is for the Specification:

A74-2834 [1] .001 **X** **-**

Which comprises of the following SubComponents:

Electrical Testing					
ETR 1901.000	X	Validated	20/10/2016 02:03:00	ETR 1901.000.pdf	1
ETE 1901	00	Validated	26/04/2016 03:00:00		
Manufacturing Process					
LPR 0001(USB 3 MicM-CM).000	X	-		LPR 0001(USB 3 MicM-CM).000.pdf	1
Label on Bag (ALY CE)	00	-			
Label on Cable (Pad Print WHT)	00	-			
USB Assembly					
P74-2834[1].001	X	-		P74-2834.001.pdf	1
USB Assembly					
A86-4730(T)	02	Validated	10/03/2020 02:32:00	P74-2834.001.pdf	1
USB C (OD6.2 DCT)	00	-		A86-4730(T) (02) .pdf	1
A46-1003	00	-			
A99-3372	00	-			
USB MicB 3.0 s1 (OD5.8 DC)	00	-		USB MicB 3.0 s1 (OD5.8 mh) .pdf	1
A79-5611	01	Validated	20/07/2020 01:04:00	A79-5611(01) .pdf	1
A99-7045	00	-			



DRAWING REF: **P74-2834.001**

DRAWING REF: USB 3.0 Industrial Assembly (A+ series)

(WON 200724) Refresh Wiring Diagram

Length (L) in Meter, As per Customer Requirements (max. 5M recommended)

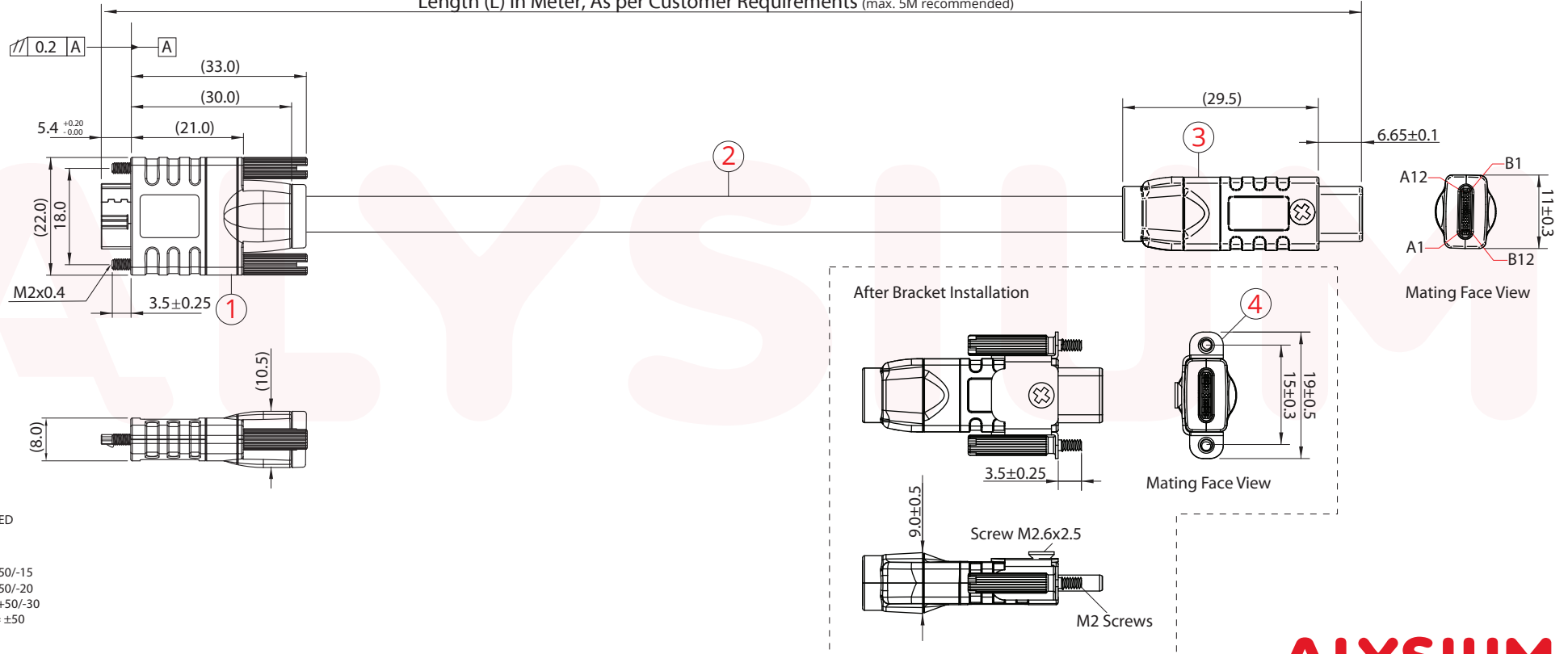

Mating Face View

Mating Face View

Mating Face View

UNIT: mm
 UNLESS OTHERWISE SPECIFIED
 ASSY LENGTH TOLERANCE
 < 150mm = +50/-10
 ≥ 150mm and < 250mm = +50/-15
 ≥ 250mm and < 500mm = +50/-20
 ≥ 500mm and < 1000mm = +50/-30
 ≥ 1000mm and < 5000mm = ±50
 5000mm and above = ±100

RoHS COMPLIANT

This document is the property of Alysium-Tech. It must not be copied or otherwise disclosed without prior written consent



BILL OF MATERIALS

Item	Description
1	A+ USB MicB 3.0 sl (OD5.8 DCT) Die Cast Shell incl.
2	A86-4730(T), [OD=6.2mm] <BLK> E357566-ALY-T UL2725 2STP(#26x2C)+STP#28+2C#22
3	A+ USB TypeC (OD6.2 DCT) Die Cast Shell incl.
4	M2.6x2.5 screw (to be disposed, when bracket is applied) USB C (DC) Bracket

WIRING DIAGRAM

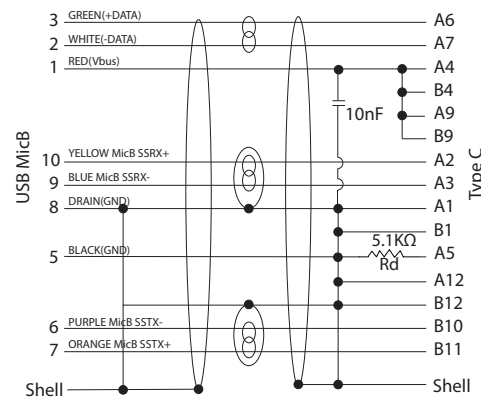

ACCESSORIES DETAILS

This assembly consists of below accessories:
 A) Metal sheet bracket for USB TypeC (1pc).
 B) M2 thumb screws (pre-Installed in Type C brackets) (2pcs).
 C) M2.6x3.0 flat head screw (pre-Installed in TypeC termination) (1pc).

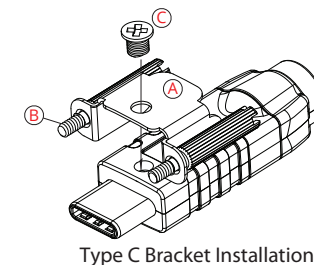

Type C Bracket Installation



Cable Assembly Example:

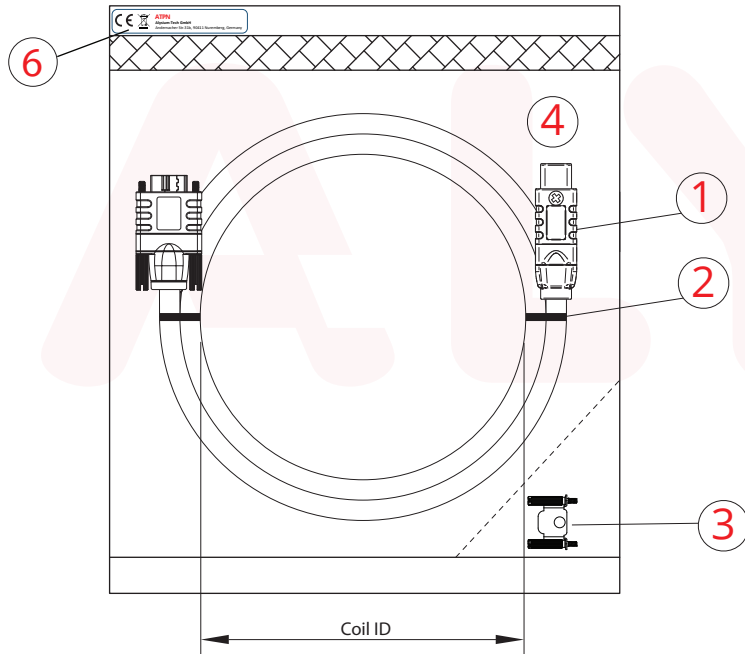

Packaging Content:

- | | |
|-----------------------------|--|
| 1) Basic Assembly | 1pc |
| 2) Magic Tie/ Cable Tie | 2pcs |
| 3) Accessories | 1pc (A+ USB Type C Screw Lock Bracket) |
| 4) PE Bag | 1pc |
| 5) White Pad Print on Cable | 1ps |
| 6) Label On Bag (ALY CE) | 1pc |

Table 1: Assembly Coiling Inner Diameter (Unless Otherwise Specified)

Type of Cable [Jacket OD(mm)]	Coil ID (mm)
A87-3502[9.45]	250
A86-1684(T)[5.8]	150
A86-4730(T)[6.2]	150
MCD-USB-211[7.3]	250
MCD-USB-213[7.4]	250
MCD-USB-209B[7.4]	250
A86-8365 [7.5]	150

Cable Label Guideline

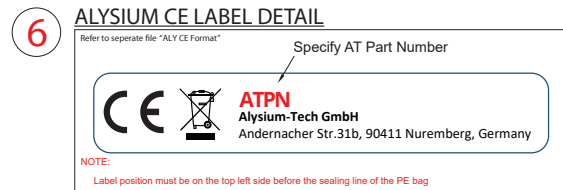
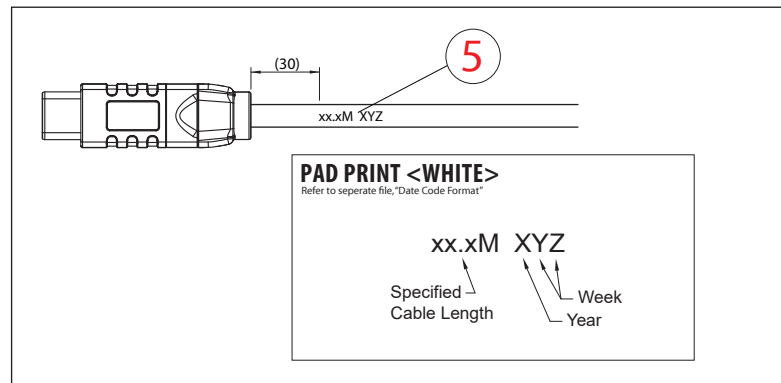

Electrical Test Criteria

- 1) Open/Short circuit
- 2) Intermittent
- 3) Insulation Resistance

Hi Pot Tester Model
HB-550 (ATPN : ETE 1901)

Measurement Parameters

Voltage = 300VDC,
Insulation Resistance > 20M Ohm,
Time = 0.1s

Sampling size

100% Check

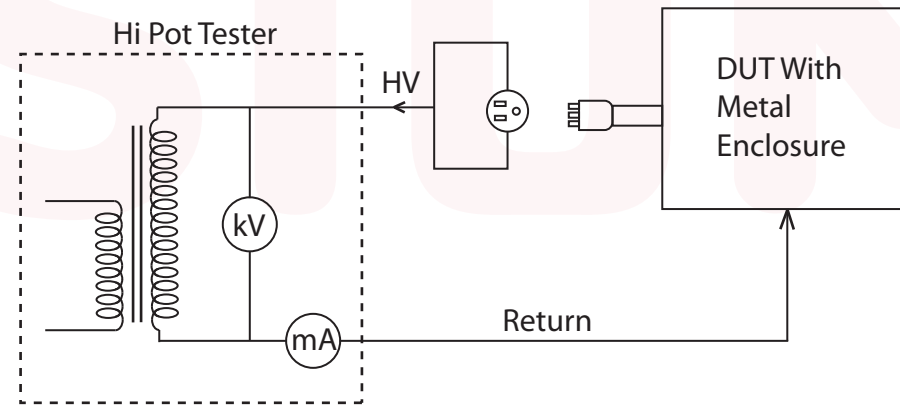

Simulated Line Leakage Diagram